

REVISIONS					
P.	LTN.	DESCRIPTION	DATE	DWN.	APVD.
K		REV PER ECO-14-016319	23OCT2014	LL	SH
L		REV PER ECO-15-010136	10JUL2015	LL	SH

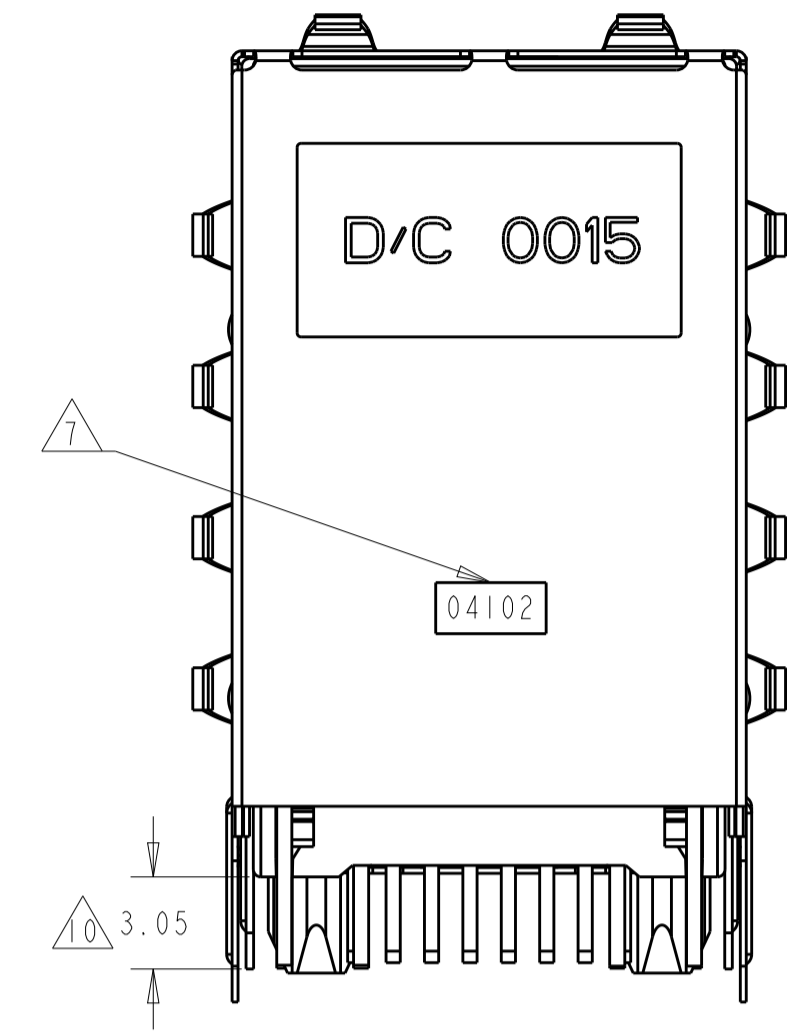

- MATERIAL: **HOUSING** - PBT POLYESTER, BLACK, UL 94V-0.
TERMINALS - 0.33 THICK PHOSPHOR BRONZE PLATED WITH 1.27um MINIMUM THICK HARD GOLD IN LOCALIZED MATING INTERFACE AND 3.81um MINIMUM THICK MATTE TIN IN SOLDER AREA OVER 1.27um MINIMUM THICK NICKEL UNDERPLATE.
SHIELD - 0.196 THICK COPPER ALLOY PLATED WITH 1.27 um [1.000050] MINIMUM NICKEL AND 2.03 um [1.000080] MINIMUM HOT TIN DIP ON PCB GROUND TABS..
LIGHT EMITTING DIODE (LED) - DIFUSED EPOXY LENS, 0.51 X 0.51 CARBON STEEL WIREFRAME LEADS PREPLATED WITH 8.89 um THICK Sn/Cu OVER 2.03 um THICK Ag OVER 1.02 THICK Cu OVER 3.56 um THICK Ni OVER 1.02 um Cu UNDERPLATE
- JACK CAVITY CONFORMS TO FCC RULES AND REGULATIONS, PART 68 SUBPART F.
- SUGGESTED OPERATING CURRENT FOR THE LED IS 20mA. GREEN/ORANGE BI-COLOR LEDS ON 6368011-4 AND 1-6368011-0 WILL EMIT GREEN LIGHT ON FORWARD BIAS CURRENT AND ORANGE LIGHT ON REVERSE BIAS CURRENT. GREEN/RED BI-COLOR LEDS ON 6368011-9 AND 1-6368011-0 WILL EMIT GREEN LIGHT ON FORWARD BIAS CURRENT AND RED LIGHT ON REVERSE BIAS CURRENT. GREEN/YEL BI-COLOR LEDS ON 1-6368011-1 WILL EMIT GREEN LIGHT ON FORWARD BIAS CURRENT AND YELLOW LIGHT ON REVERSE BIAS CURRENT.
- THIS MODULAR JACK WITH INTEGRATED LED IS NOT IR REFLOW SOLDERING PROCESS COMPATIBLE.
- USE NO. 30 DRILL BIT OR 3.25mm DRILL BIT WHEN PRODUCING THESE PCB HOLES.
- HM-15 LUBE APPLIED TO THE GOLD PLATED AREA OF THE TERMINALS ON 6368011-8 ONLY.
- DATE CODE LOCATED ON REAR OF PART APPROX AS SHOWN: FIRST 2 DIGITS ARE LAST 2 DIGITS OF YEAR, SECOND 2 DIGITS ARE MANUFACTURING WORK WEEK, LAST DIGIT IS DAY OF WEEK, WITH SUNDAY=1.
- THE PART NUMBER IS PRELIMINARY.
- OBSOLETE PARTS: OBSOLETE CIS STREAMLINING PER D.RENAUD/D.SINISI
- GROUND PIN AND ALL SIGNAL PINS' LENGTH SHOULD BE 4.06 MM EXCEPT OUTER SHIELD THIS REQUEST IS ONLY FOR PART 1-6368011-4

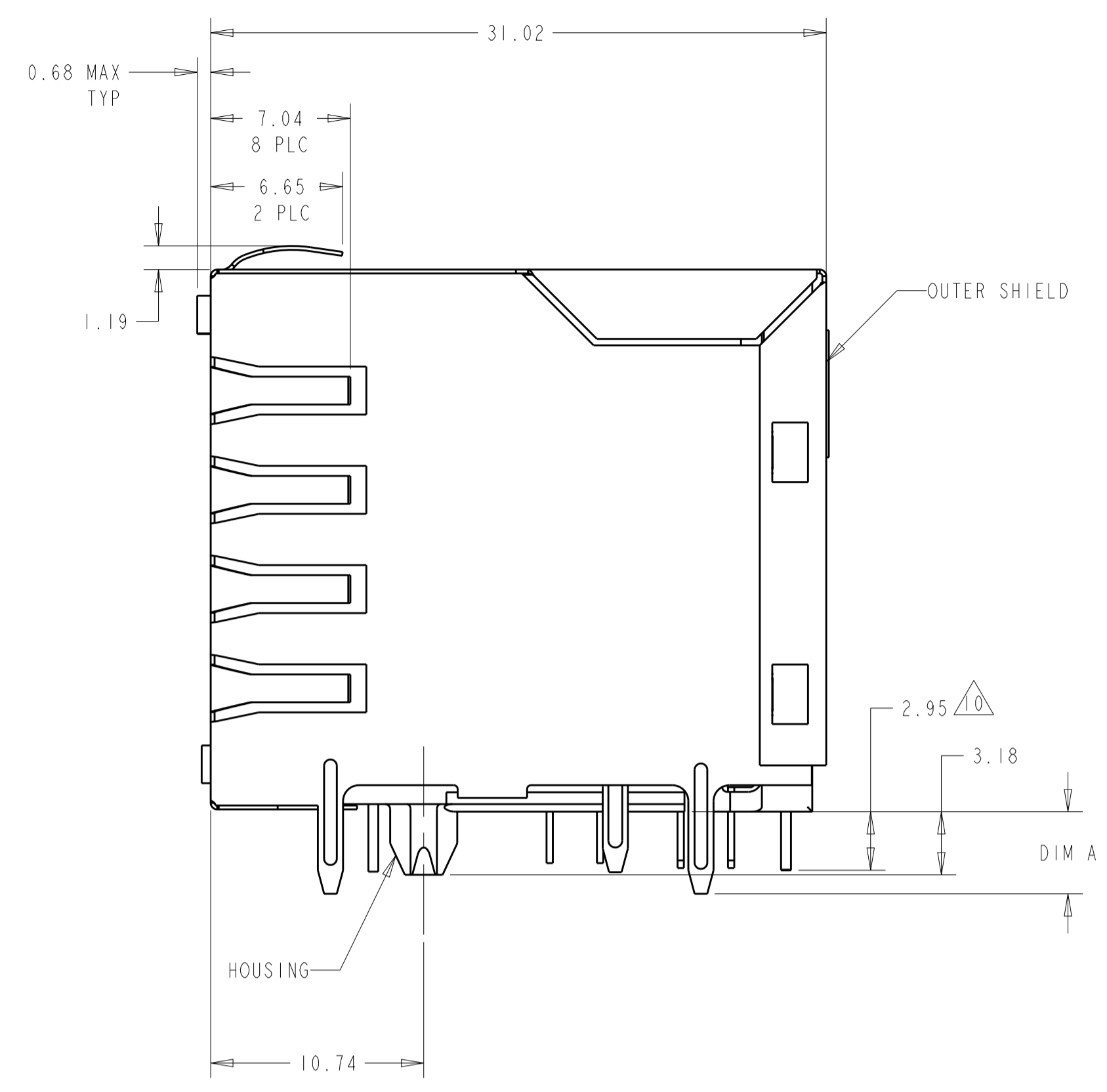
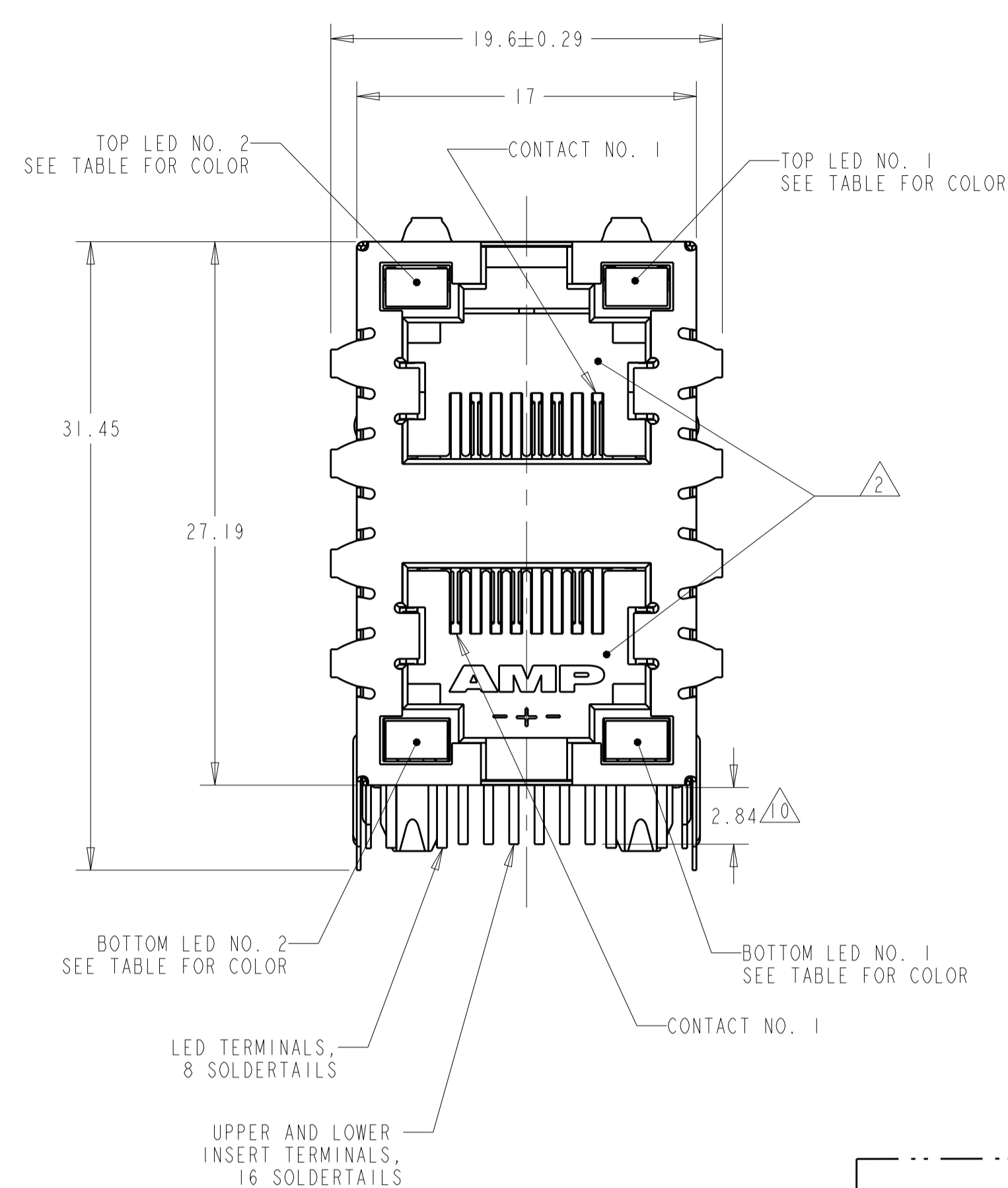
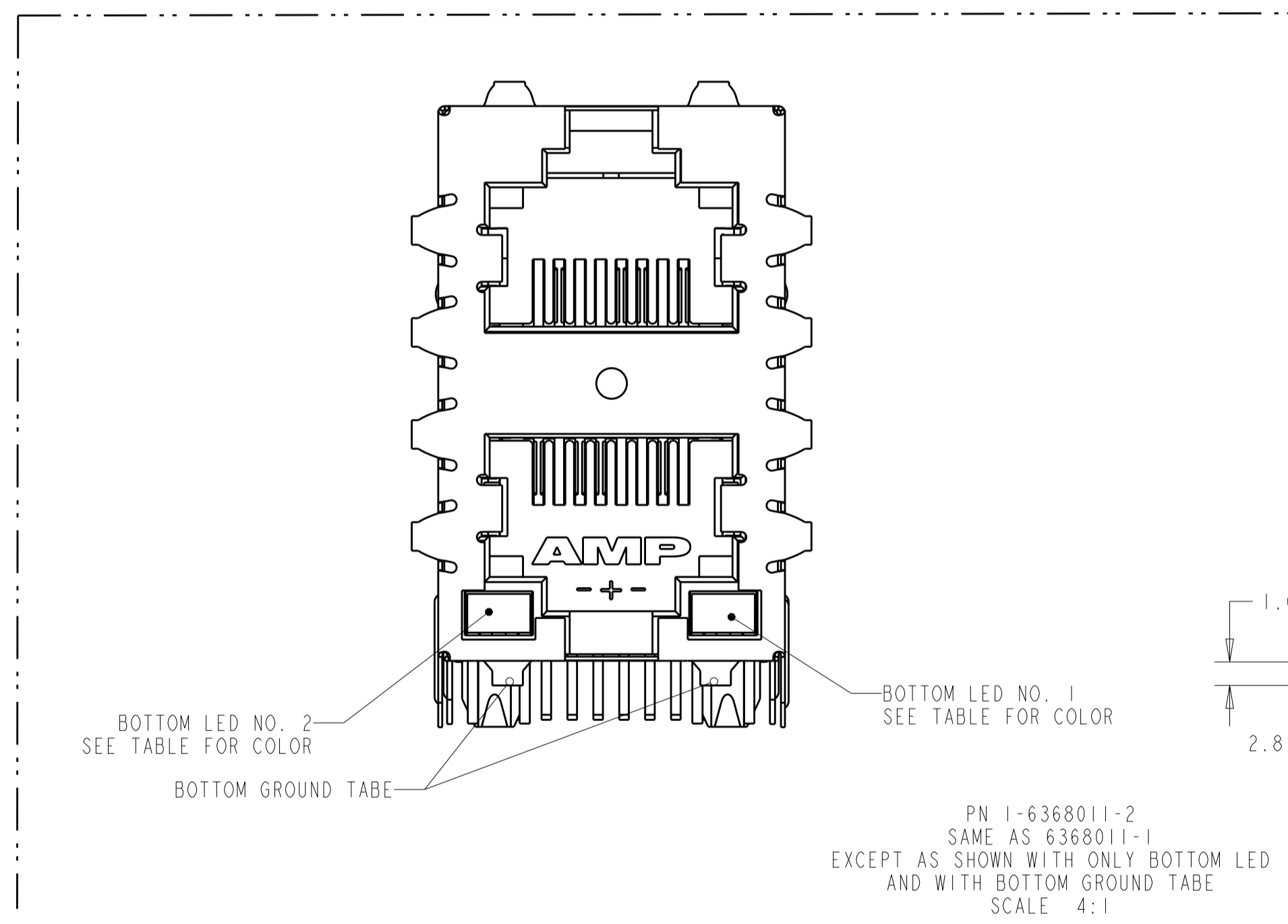
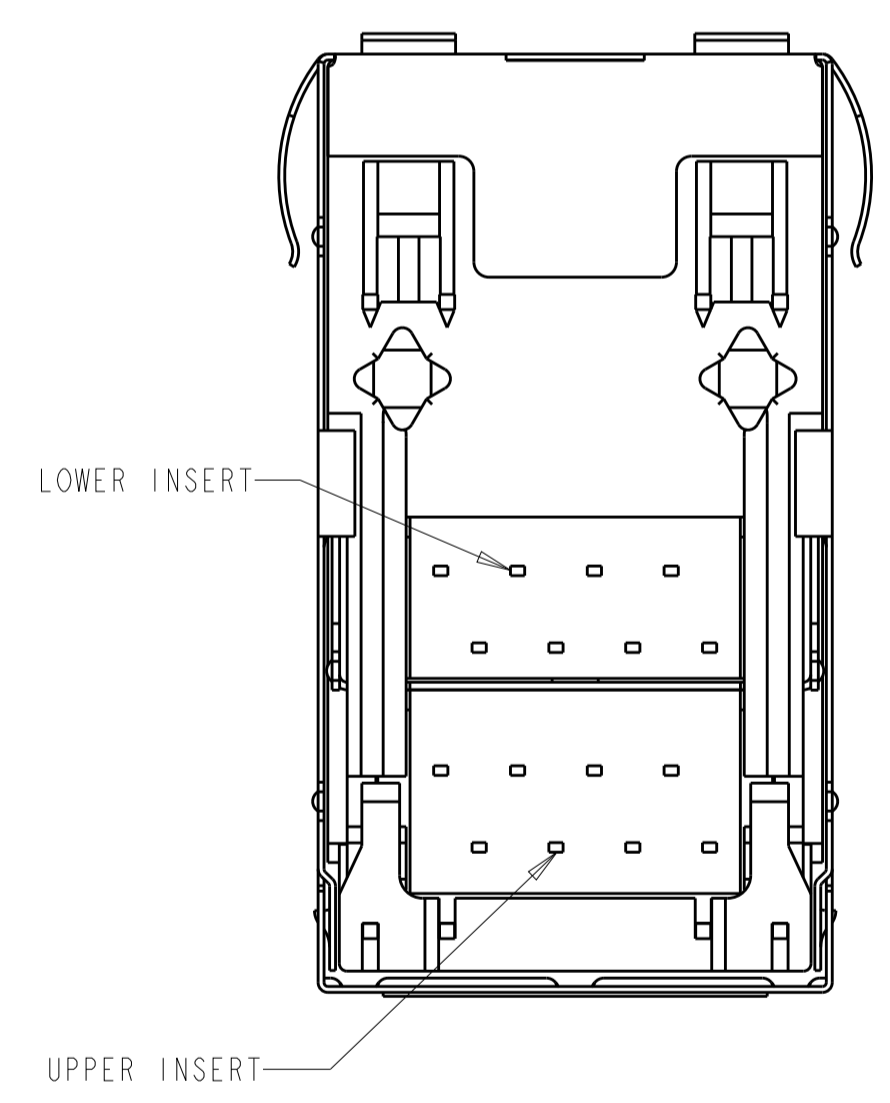

4.14	GREEN/ORANGE	GREEN/ORANGE	N/A	N/A	2-6368011-1
3.44 MAX	GREEN	GREEN	GREEN	GREEN	1-6368011-5
4.14	GREEN	YELLOW	GREEN	YELLOW	1-6368011-4
4.14	GREEN	YELLOW	N/A	N/A	1-6368011-3/8
3.175	GREEN	ORANGE	N/A	N/A	1-6368011-2
4.14	GREEN/YELLOW	GREEN/YELLOW	GREEN/YELLOW	GREEN/YELLOW	1-6368011-1
4.14	GREEN/ORANGE	GREEN/ORANGE	GREEN/RED	GREEN/RED	1-6368011-0
4.14	GREEN/RED	GREEN/RED	GREEN/RED	GREEN/RED	6368011-9
4.14	YELLOW	GREEN	YELLOW	GREEN	6368011-8/6
4.14	GREEN	ORANGE	N/A	N/A	6368011-7
	GREEN	GREEN	YELLOW	GREEN	6368011-6
4.14	YELLOW	GREEN	YELLOW	GREEN	6368011-5
4.14	GREEN/ORANGE	GREEN/ORANGE	GREEN/ORANGE	GREEN/ORANGE	6368011-4
4.14	GREEN	YELLOW	GREEN	YELLOW	6368011-3
	YELLOW	GREEN	GREEN	YELLOW	6368011-2
4.14	GREEN	GREEN	GREEN	GREEN	6368011-1

△ 9 OBSOLETE

△ 9 OBSOLETE

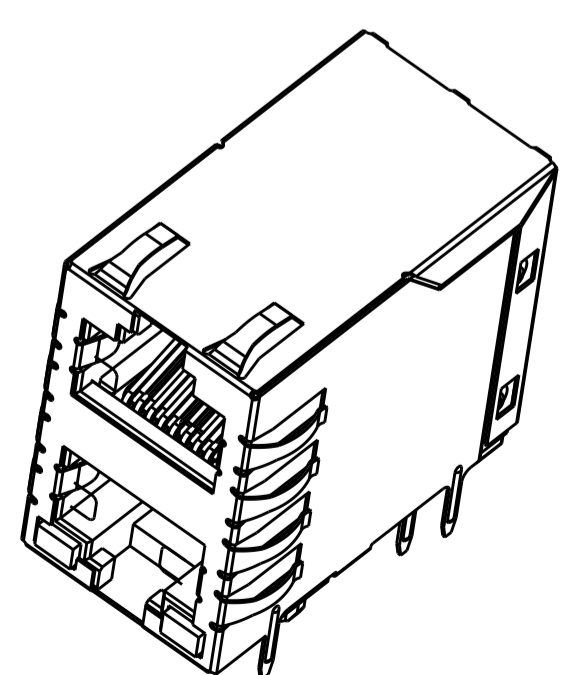
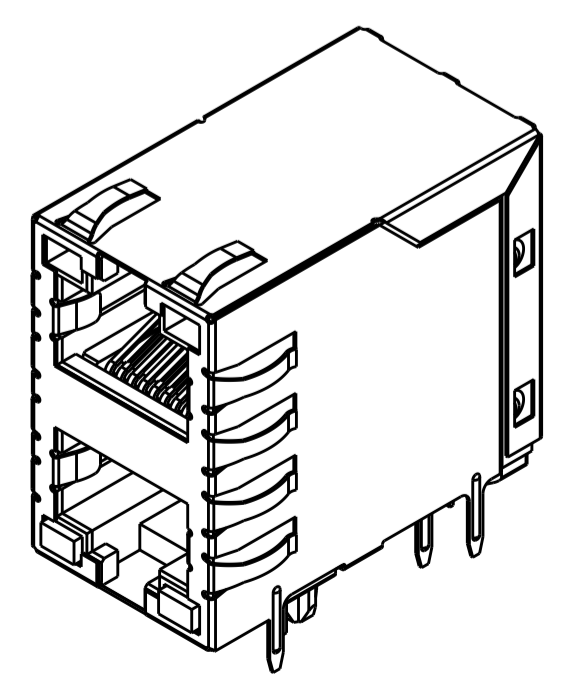
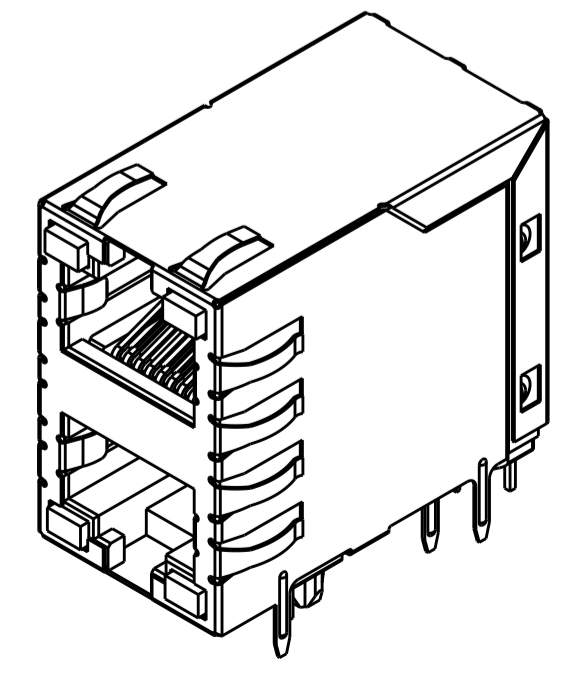

THIS DRAWING IS A CONTROLLED DOCUMENT.

DIMENSIONS: mm

TOLERANCES UNLESS OTHERWISE SPECIFIED:

0 PLC	±
1 PLC	±
2 PLC	±0.25
3 PLC	±0.25
4 PLC	±
ANGLES	±

MATERIAL: SEE NOTE 1

FINISH: SEE NOTE 1

WEIGHT: -

Customer Drawing

DWN: Vik Slack/JA MAYER
CHK: J.WESTMAN
APVD: S.FLICKINGER

DATE: 13APR2005

NAME: S.FLICKINGER

PRODUCT SPEC: 108-1163-2

APPLICATION SPEC: 114-2154

SIZE: A1

CAGE CODE: 00779

DRAWING NO: 6368011

RESTRICTED TO: -

SCALE: 4:1

SHEET: 1 OF 3

REV: L

REVISIONS				
P.	LTN.	DESCRIPTION	DATE	APVD.
-	-	SEE SHEET 1	-	-

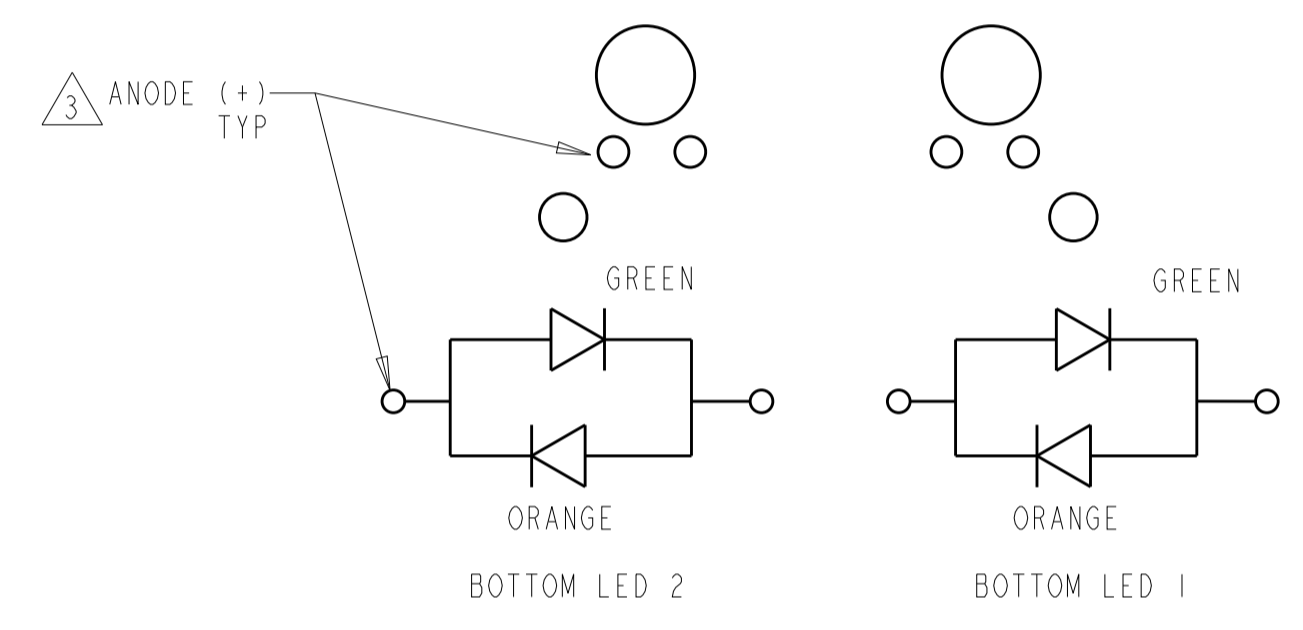
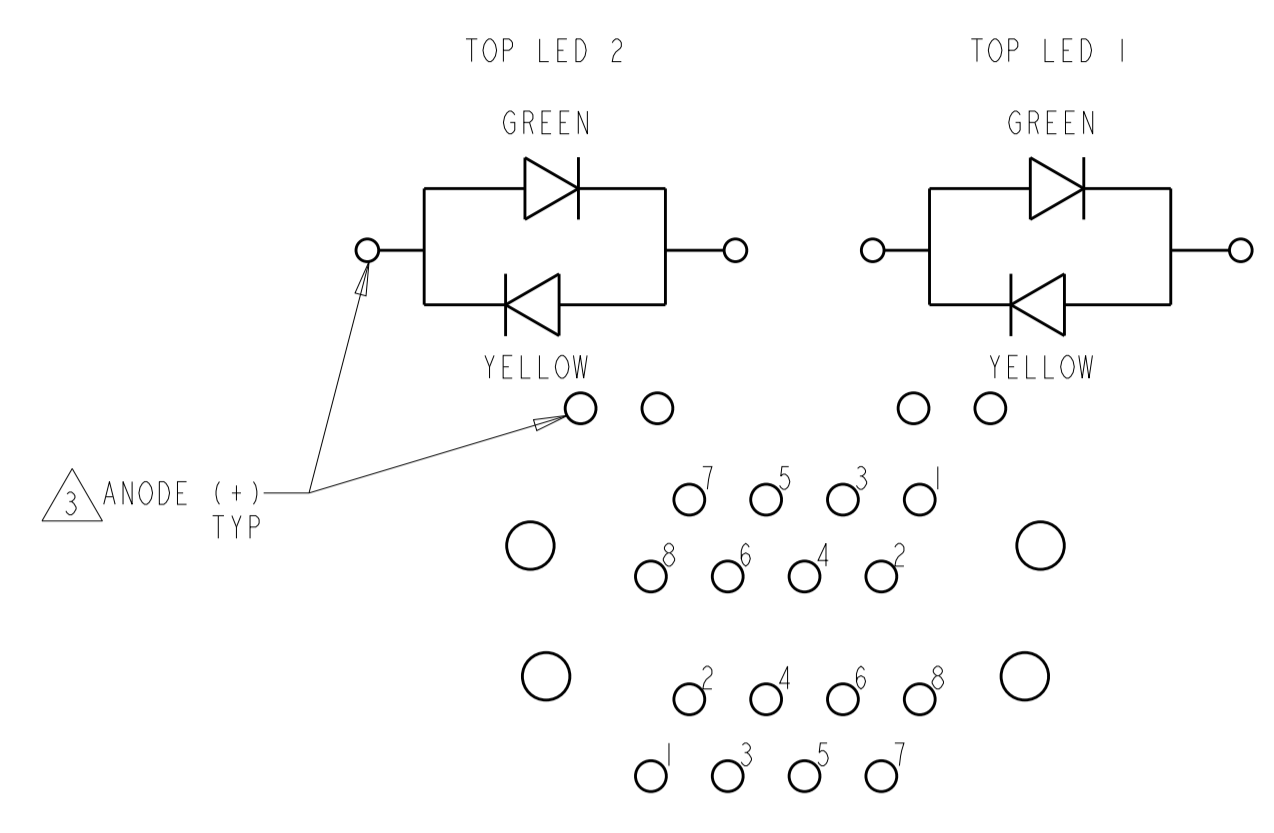
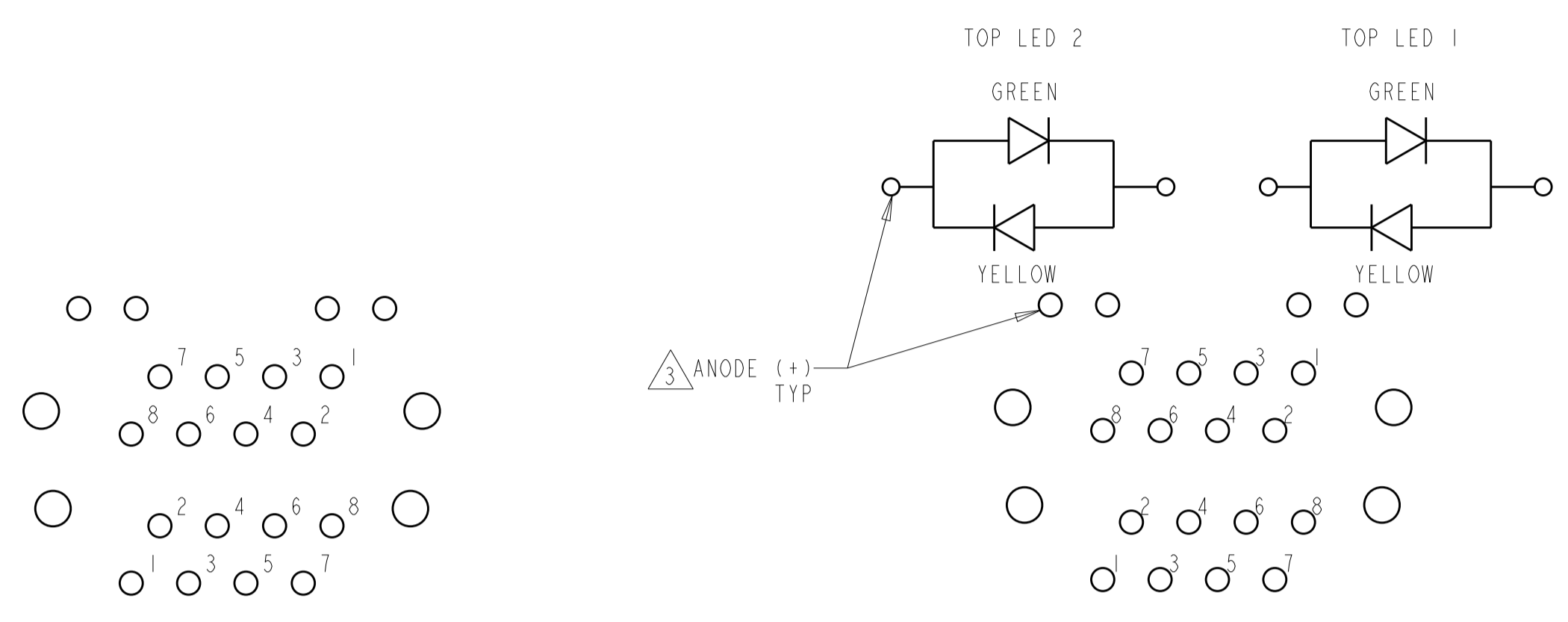

SCHEMATIC FOR 2-6368011-1
SCALE 4:1

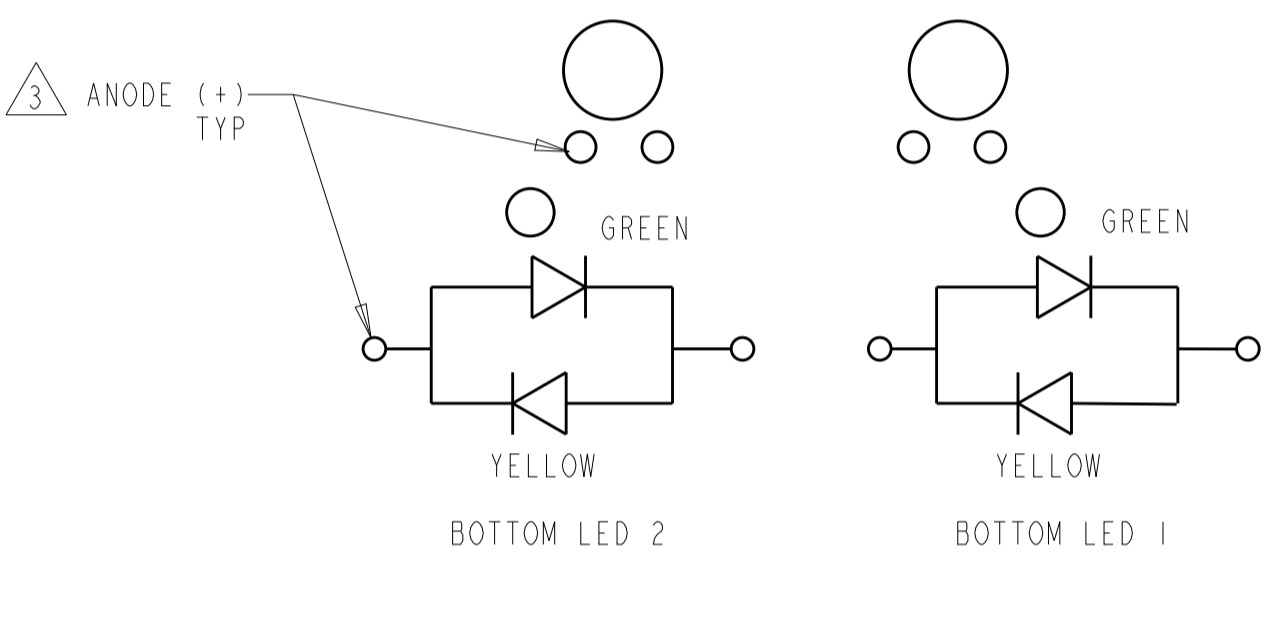

SCHEMATIC FOR 1-6368011-1
SCALE 4:1

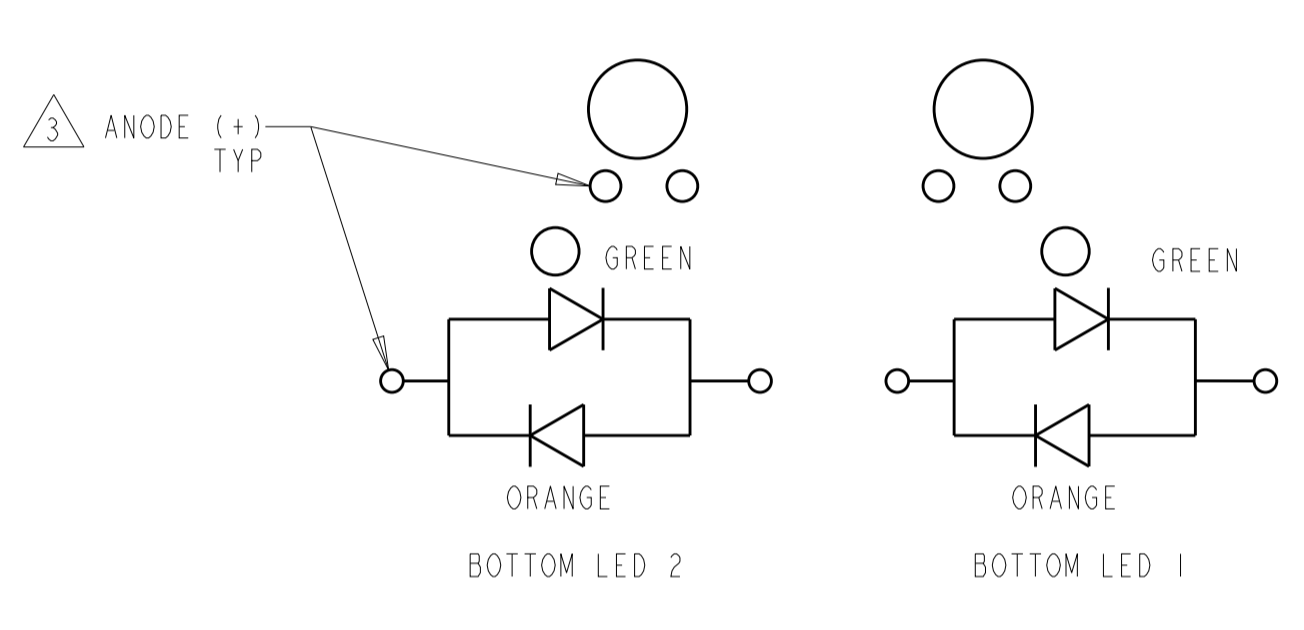
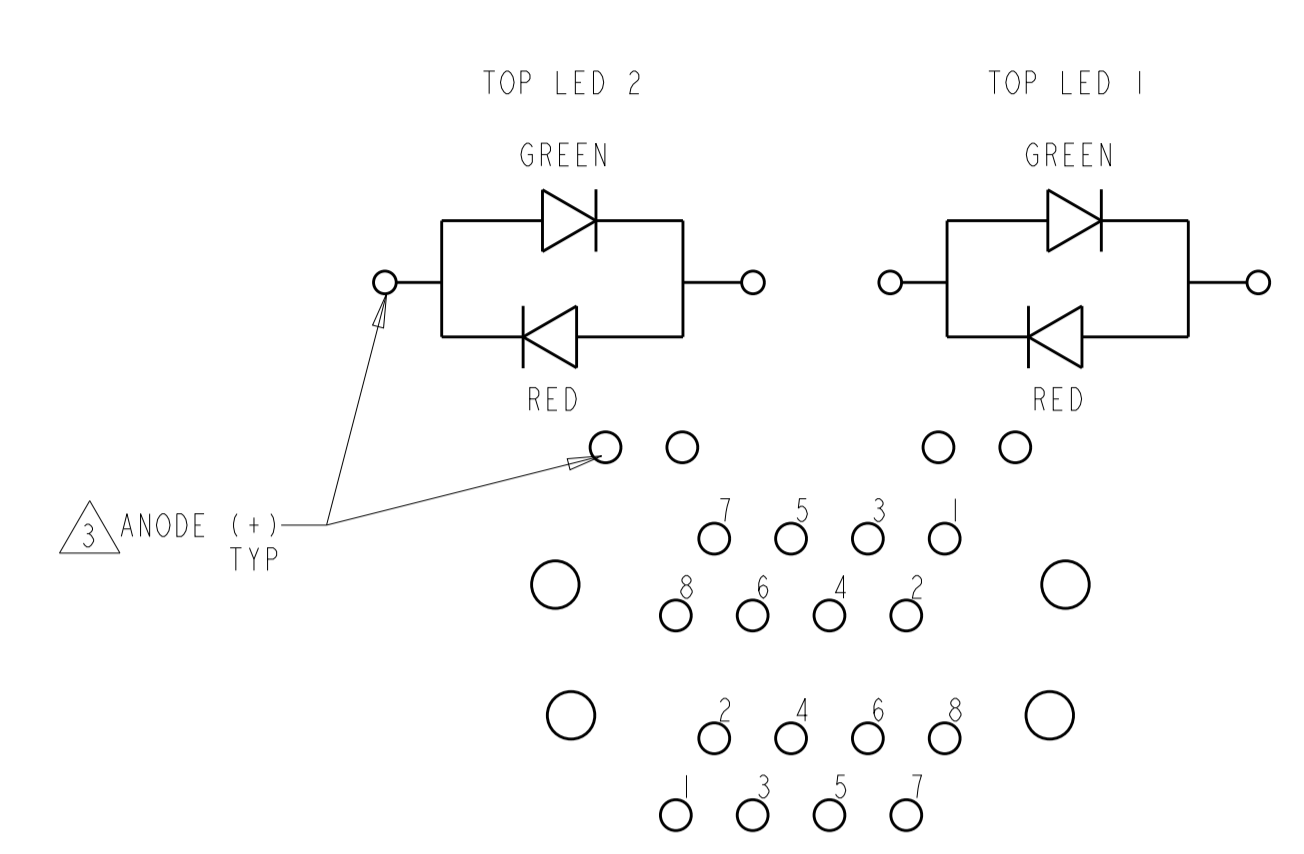
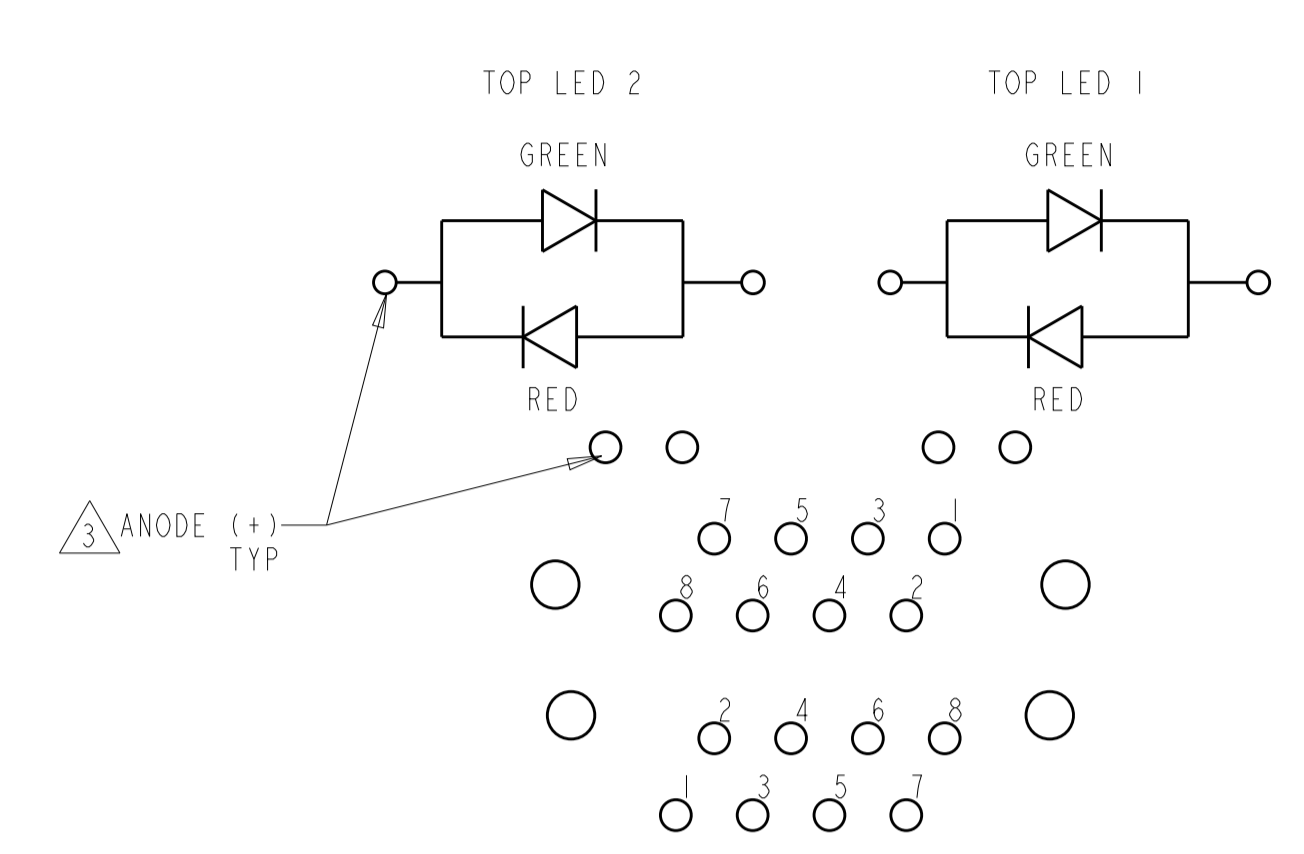

SCHEMATIC FOR 1-6368011-0
SCALE 4:1

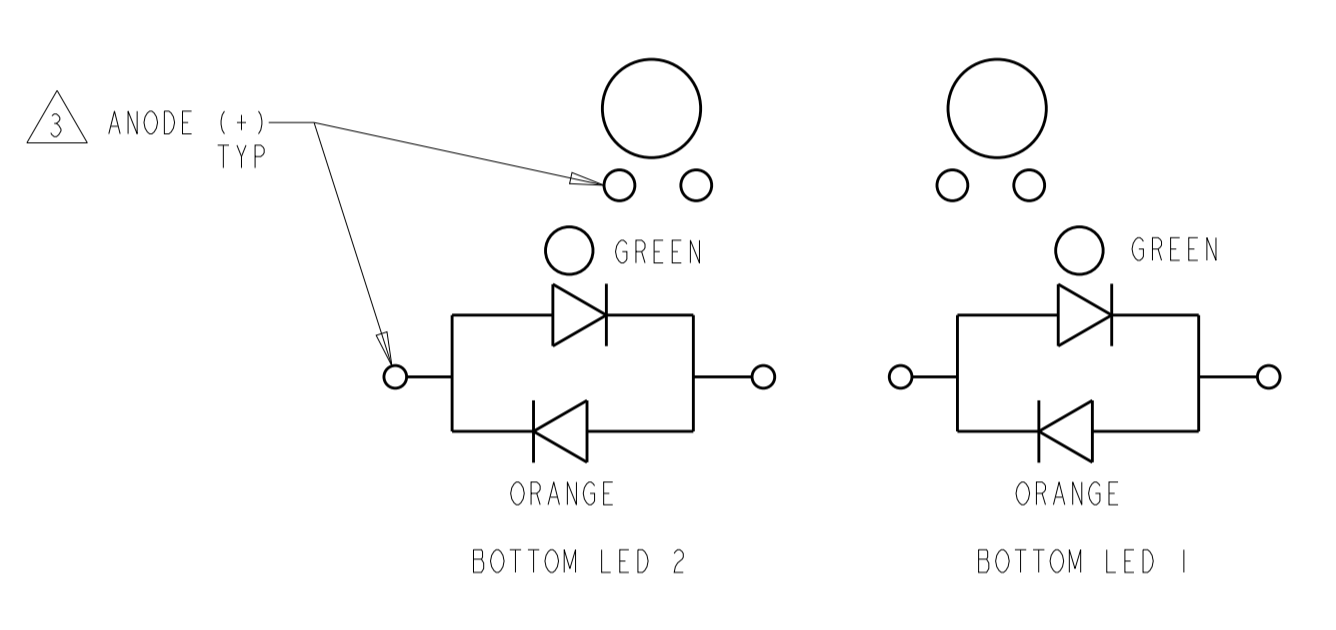
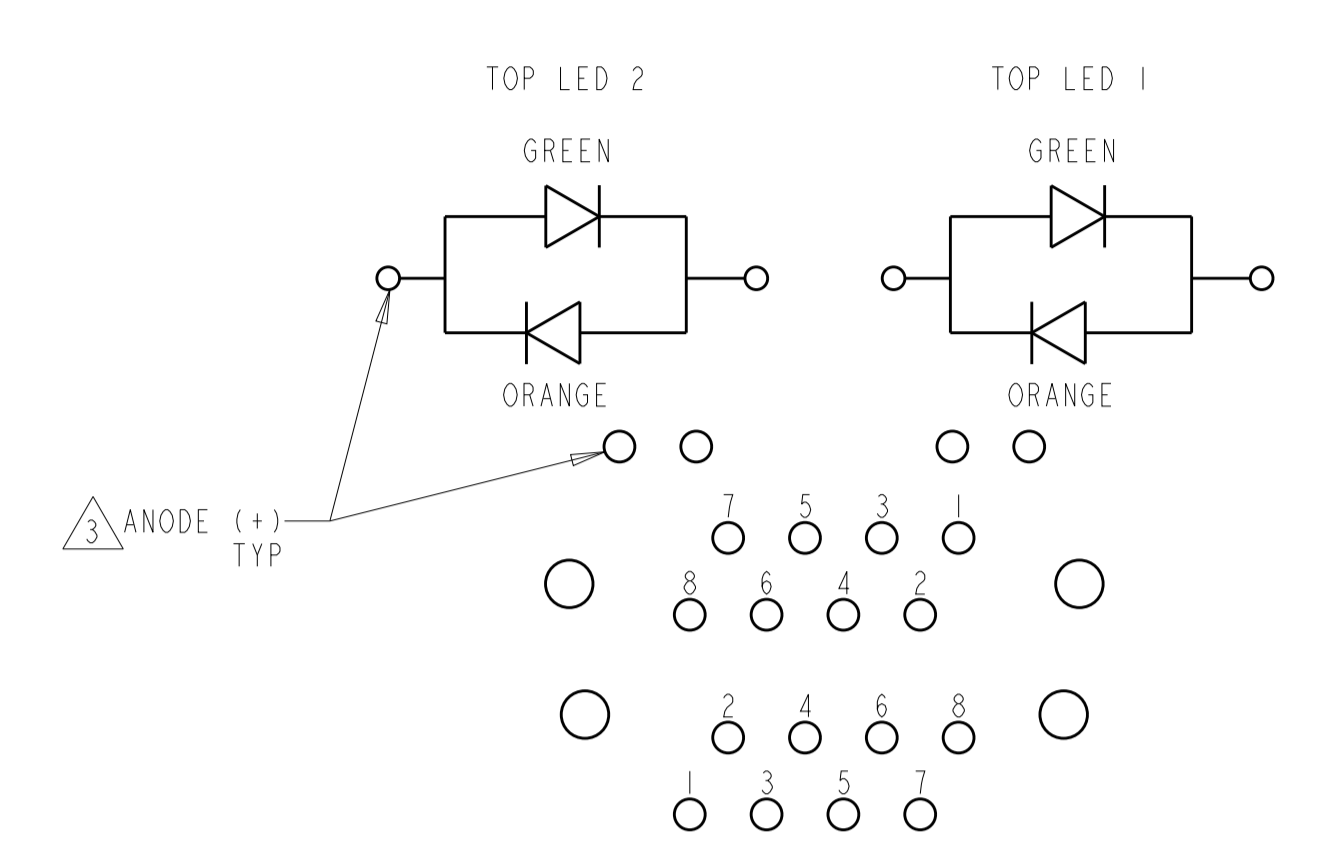
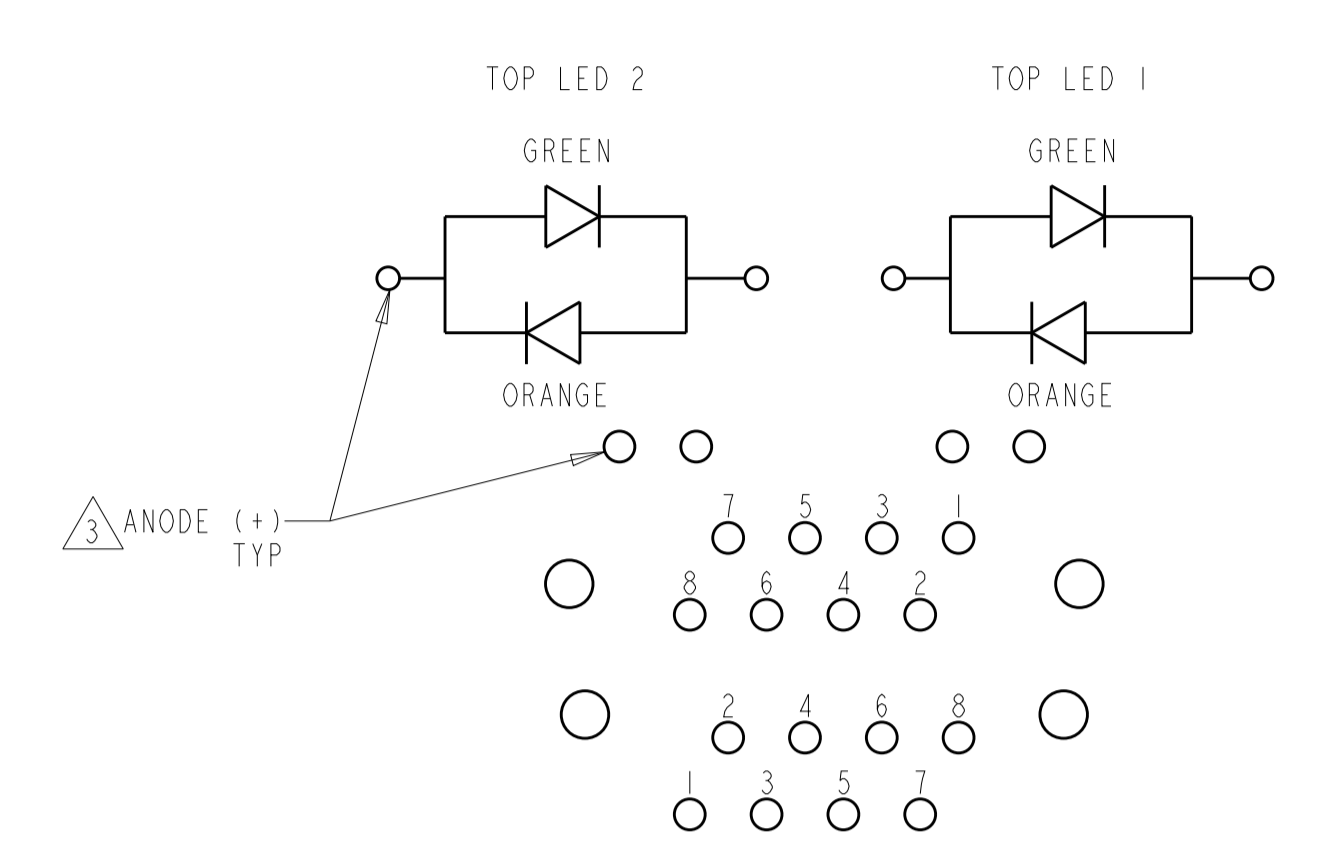

SCHEMATIC FOR 6368011-4
SCALE 4:1

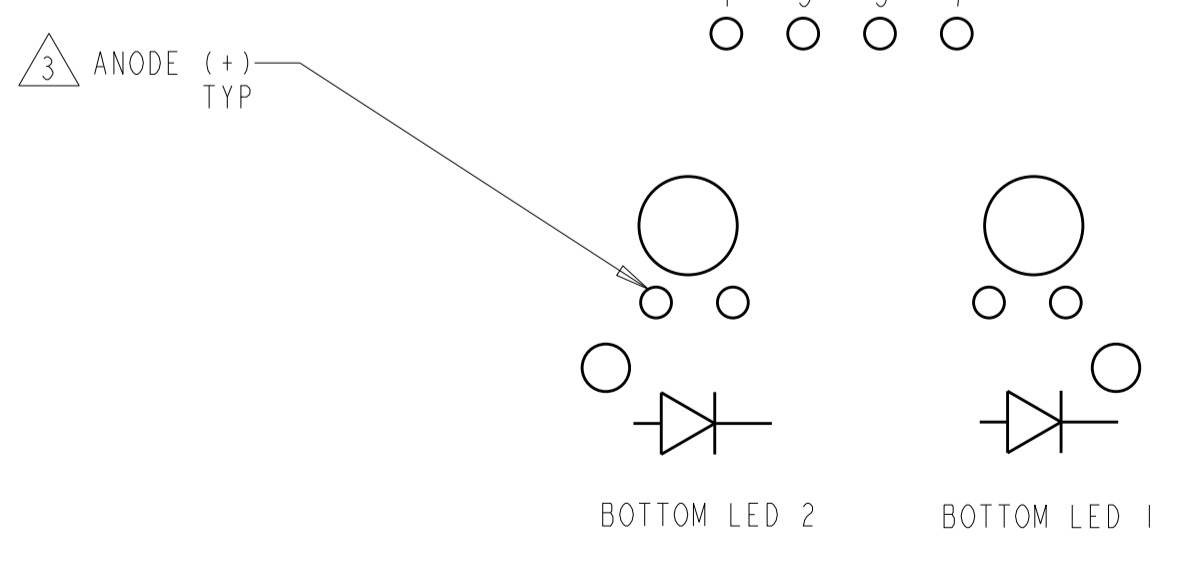
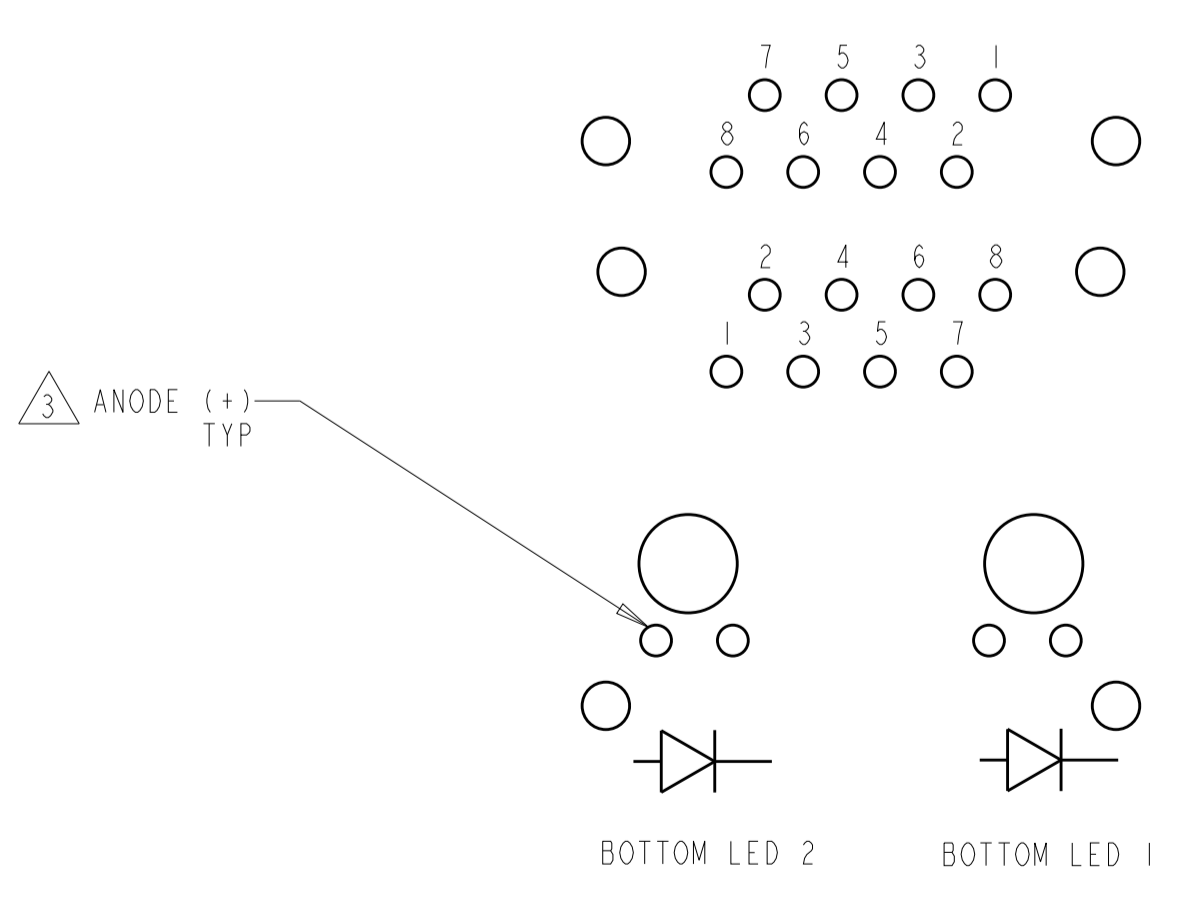

SCHEMATIC FOR 6368011-7,
1-6368011-2, 1-6368011-3

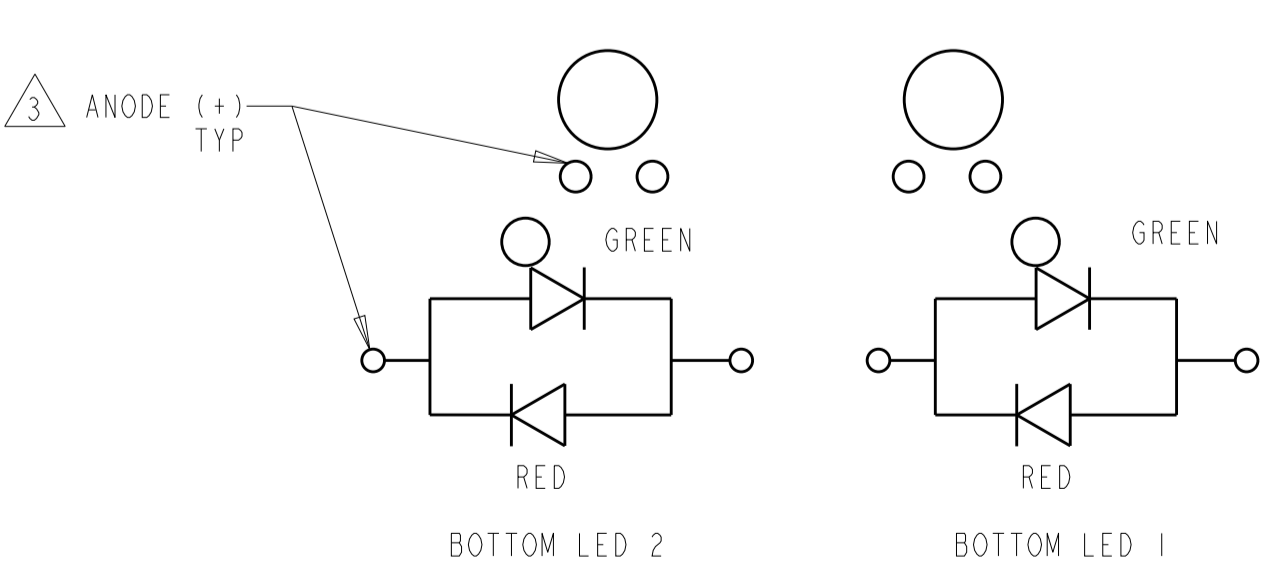
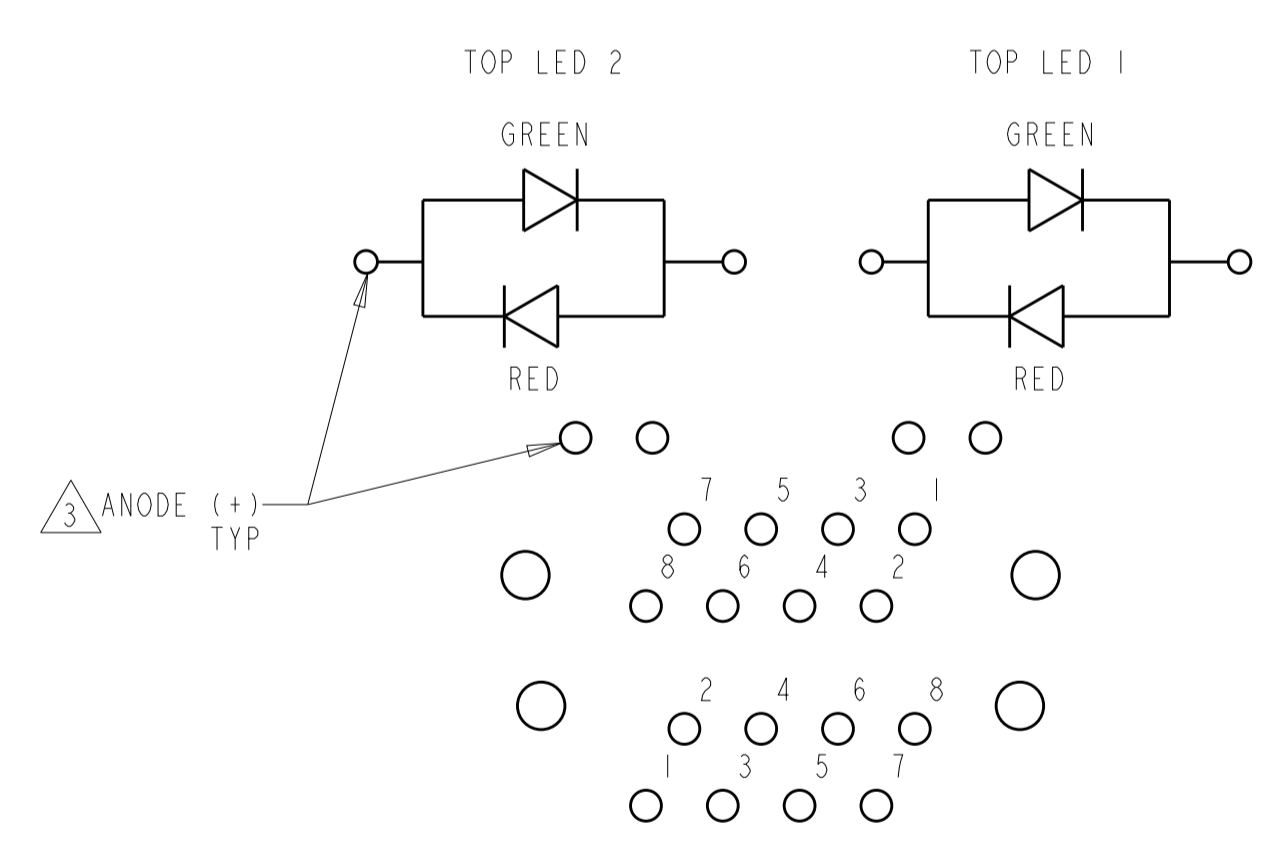
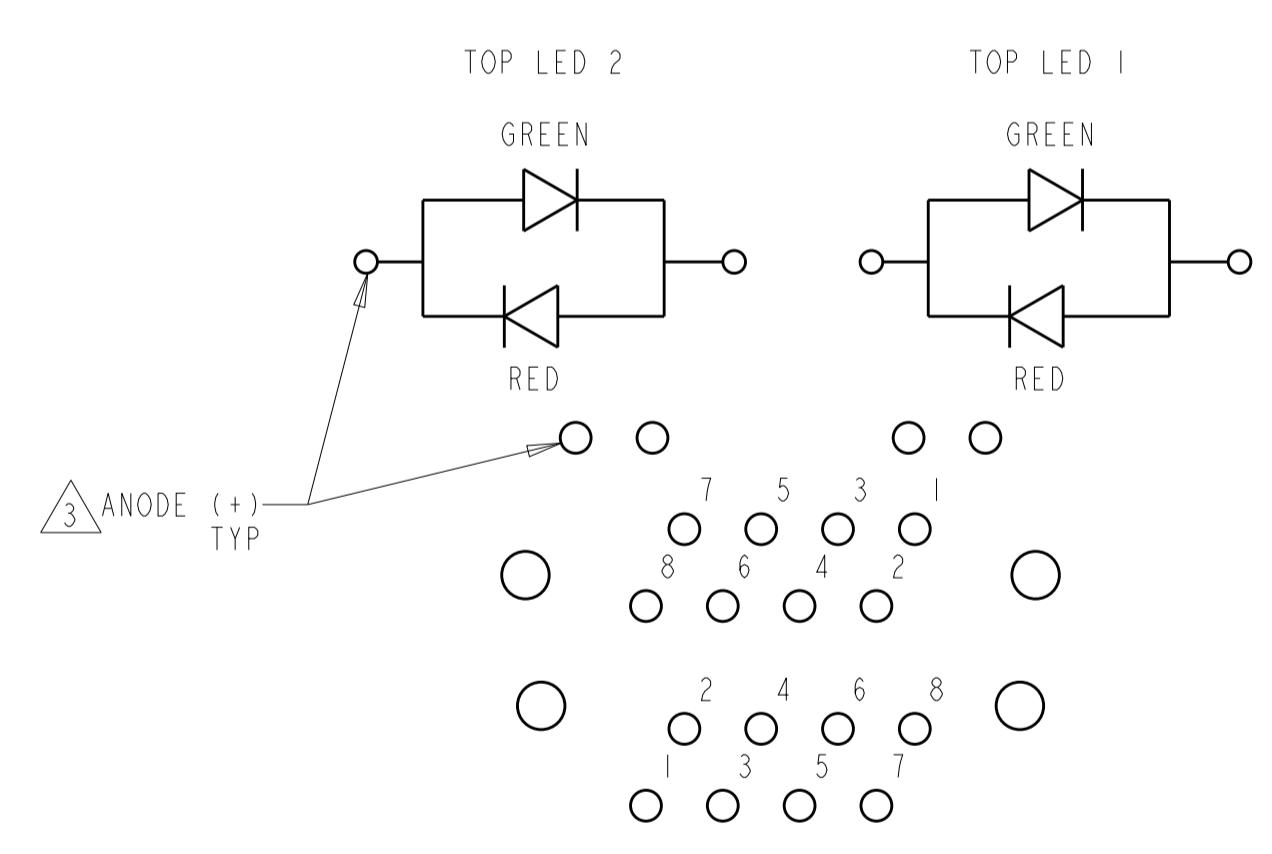

SCHEMATIC FOR 6368011-9
SCALE 4:1

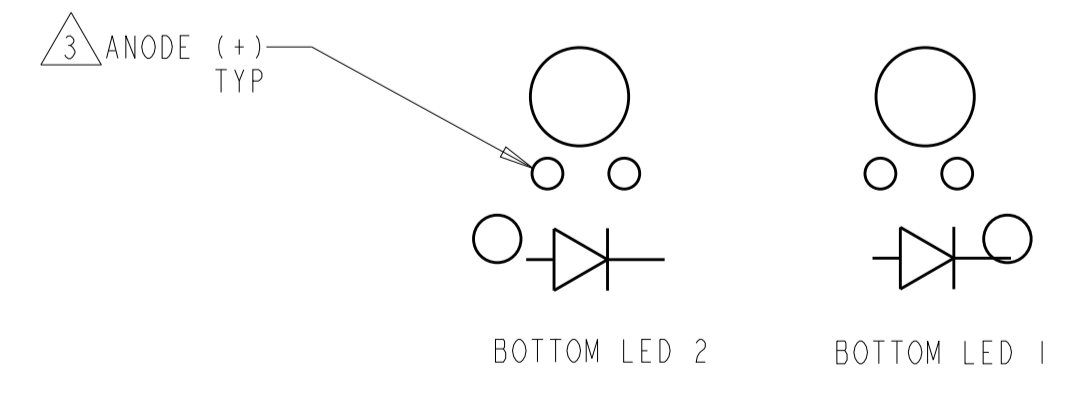
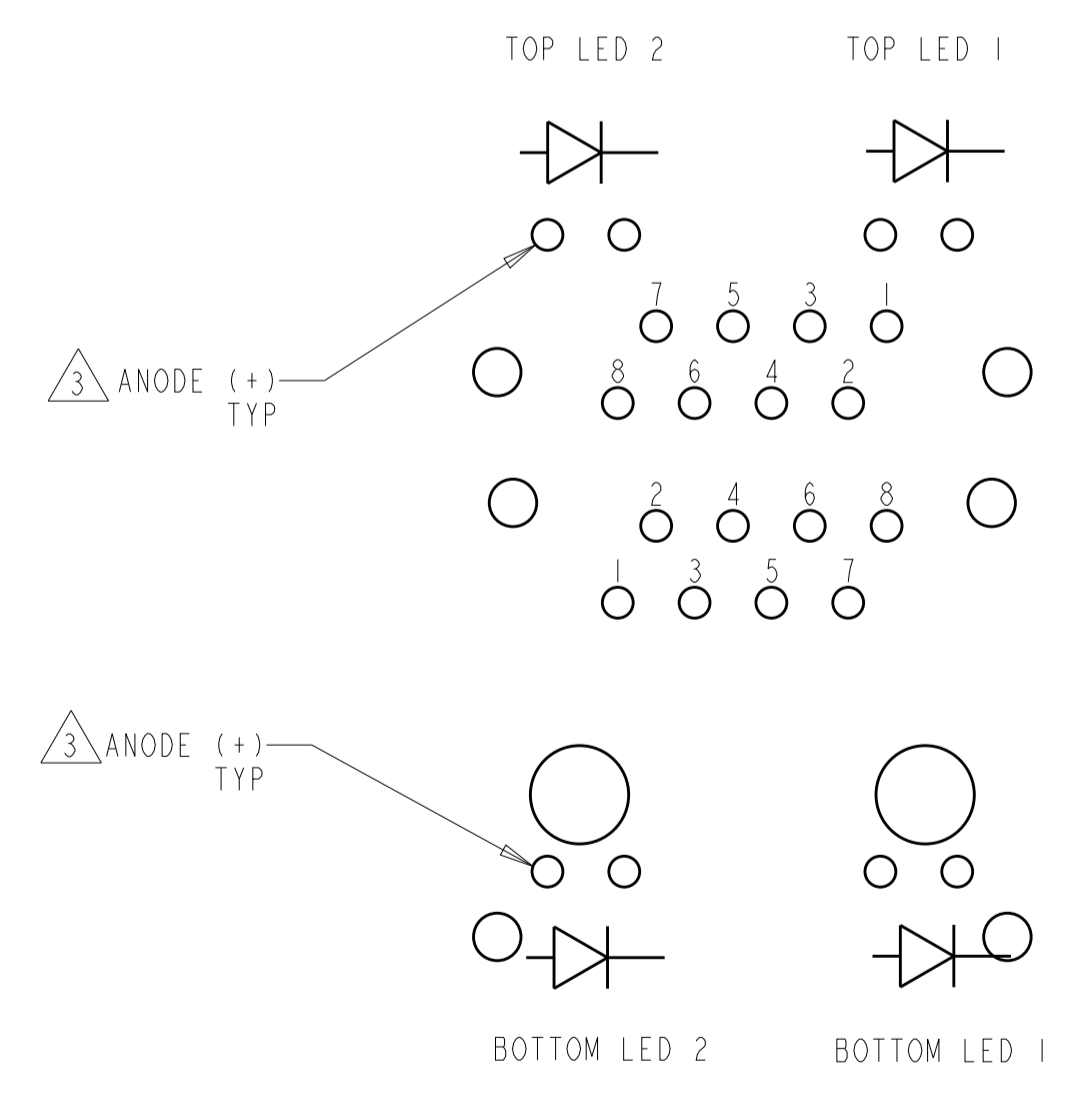
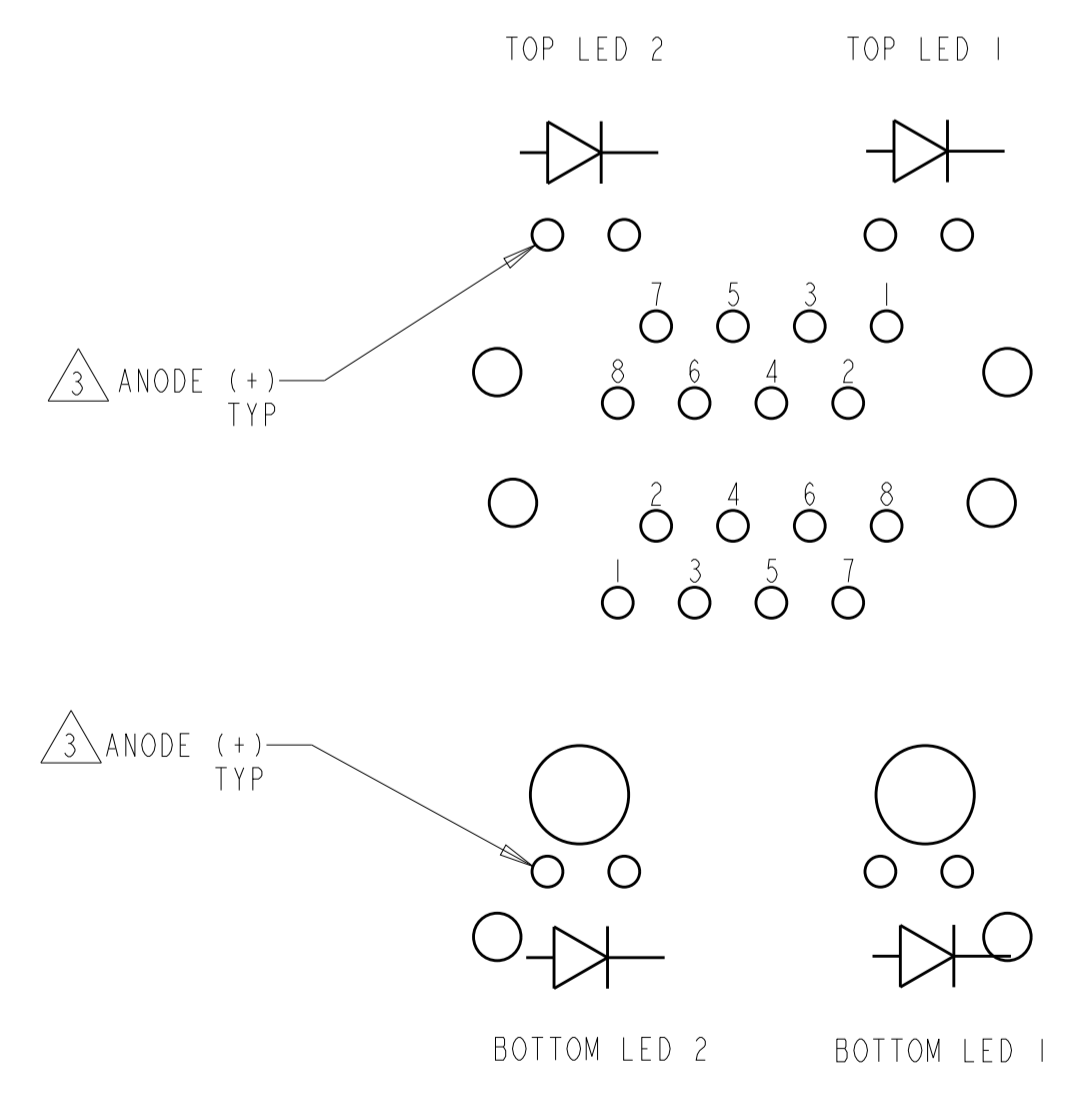

SCHEMATIC FOR 6368011-1, -2, -3, -5, -6, -8, 14
SCALE 4:1

THIS DRAWING IS A CONTROLLED DOCUMENT.		DWN: 13APR2005 CHK: Vic Slack/J. A. MATYB J. WESTMAN 13APR2005	TE Connectivity NAME MODULAR JACK ASSEMBLY, STACKED, 2 X 1, 8 POSITION, SHIELDED, PRODUCT SPEC 108-1163-2 APPLICATION SPEC 114-2154	SIZE CAGE CODE DRAWING NO. RESTRICTED TO A1 00779 ©=6368011 SCALE 4:1 SHEET 2 OF 3 REV L
DIMENSIONS:	TOLERANCES UNLESS OTHERWISE SPECIFIED:	PRODUCT SPEC APPLICATION SPEC WEIGHT Customer Drawing		
mm	0 PLC ± 2 PLC ±0.25 3 PLC ±0.25 4 PLC ± ANGLES ±	FINISH SEE NOTE 1		

REVISIONS				
P.	LTN.	DESCRIPTION	DATE	APVD.
-	-	SEE SHEET 1	-	-

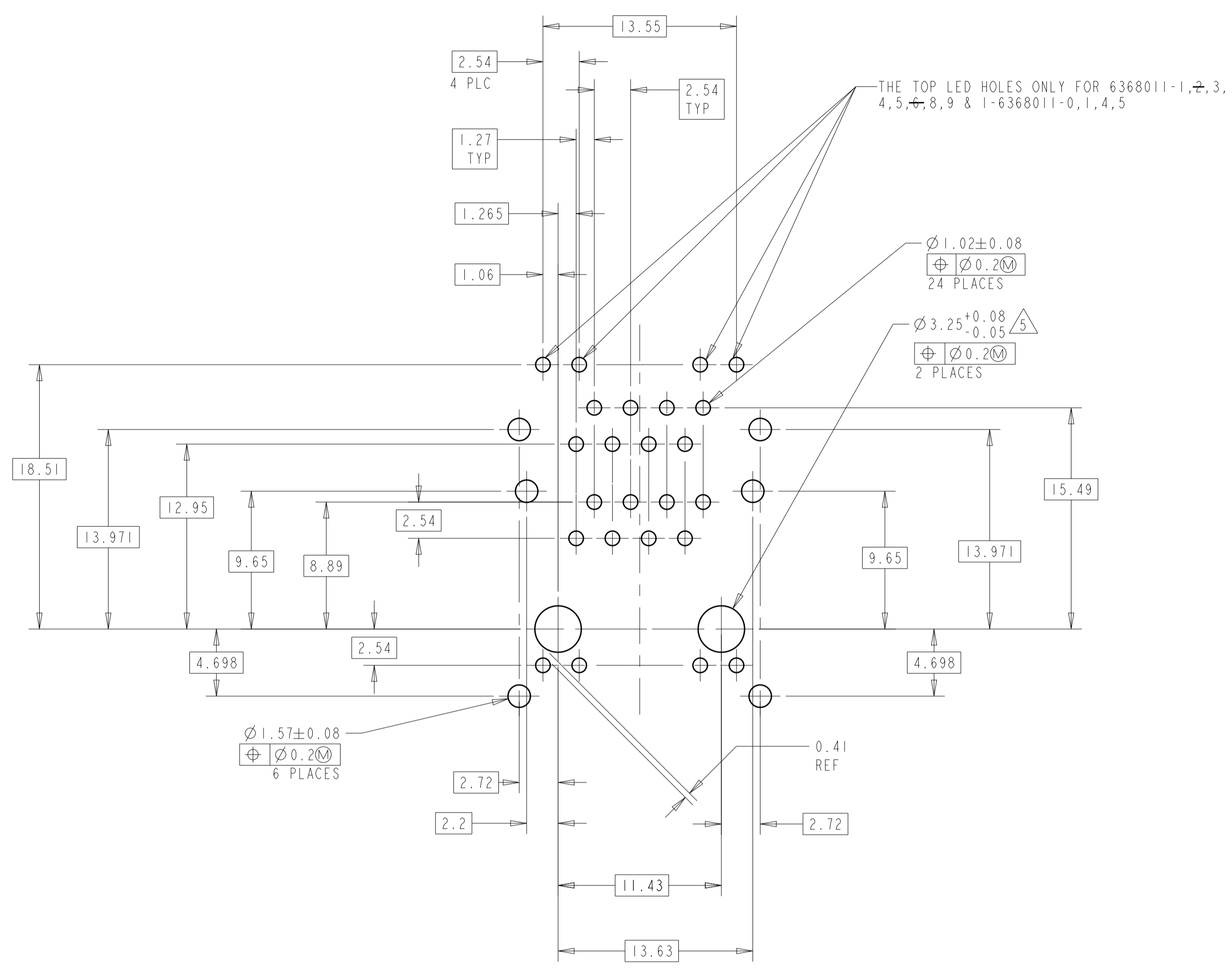

PC BOARD LAYOUT VIEWED FROM COMPONENT SIDE OF BOARD
 SCALE 4:1

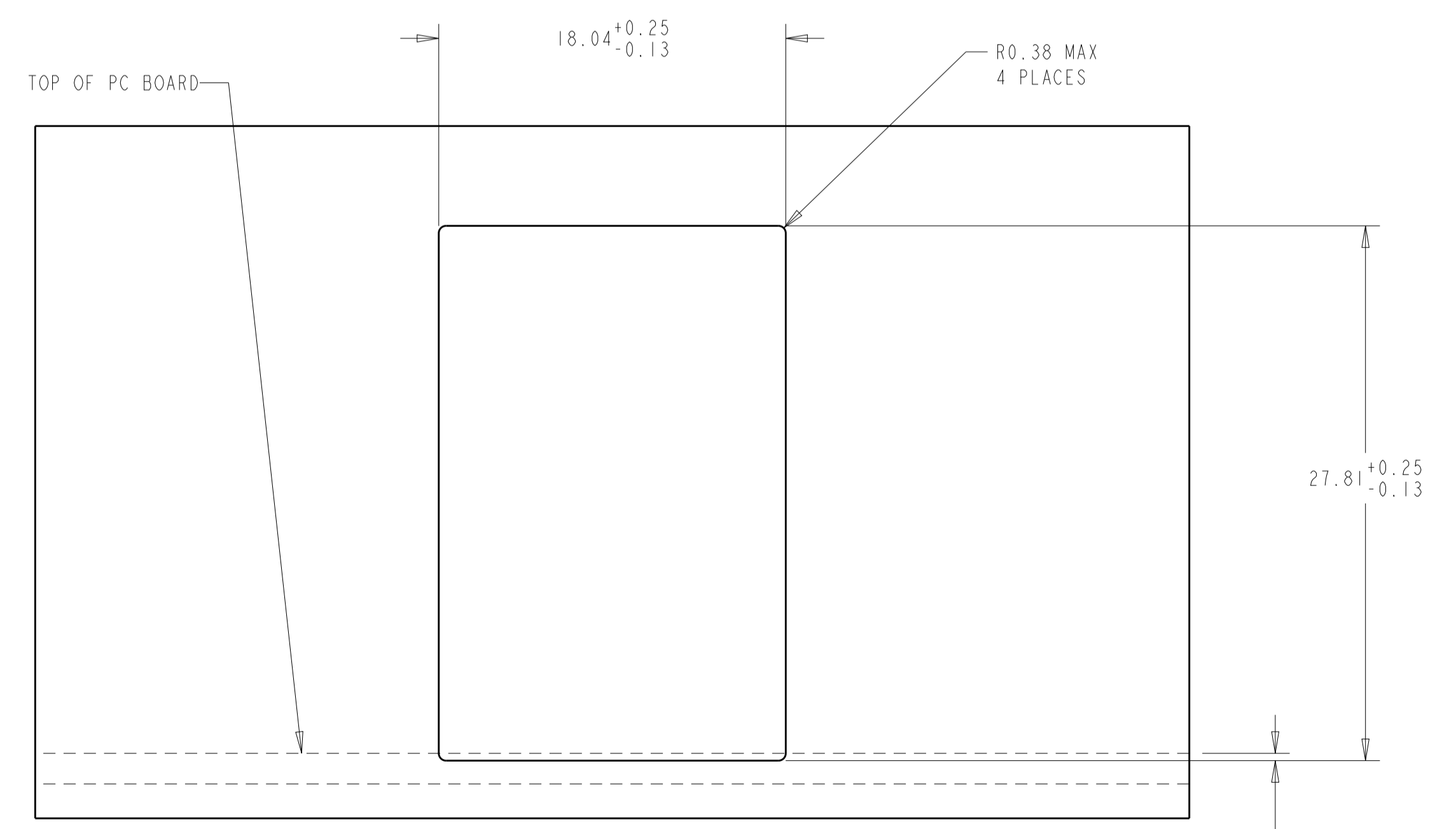

SUGGESTED PANEL CUTOUT DIMENSIONS
 SCALE 4:1

THIS DRAWING IS A CONTROLLED DOCUMENT.		DWN: 13APR2005 Vic Slack/J. A. Mayer	TE Connectivity
DIMENSIONS: mm		CHK: 13APR2005 J. WESTMAN	
TOLERANCES UNLESS OTHERWISE SPECIFIED:		APVD: 13APR2005 S. FLICKINGER	NAME: MODULAR JACK ASSEMBLY, STACKED, 2 X 1, 8 POSITION, SHIELDED,
0 PLC ±	1 PLC ±	PRODUCT SPEC	SIZE: A1
2 PLC ±0.25	3 PLC ±0.25	APPLICATION SPEC	CAGE CODE: 00779
4 PLC ±	ANGLES ±	FINISH	DRAWING NO: 6368011
MATERIAL: SEE NOTE 1	WEIGHT: -	Customer Drawing	RESTRICTED TO: -
SCALE: 4:1			SHEET: 3 OF 3